

STRAIGHT WELDING ELECTRODE
RIGHT & LEFT

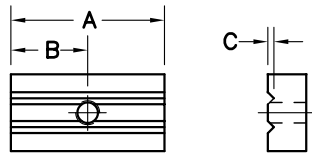

- ORDER GUIDE -
PART NO. KEY:
9701-16- A - B - C

1.0	.500	.12	1/4-5/16
1.5	.750	.08	1/8-3/16
A	B	C	WIRE DIA.

HORIZONTAL RING WELDING ELECTRODE
RIGHT & LEFT

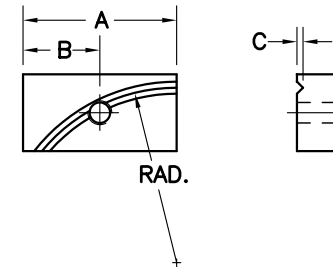

- ORDER GUIDE -
PART NO. KEY:
9701-16- A - B - C - RAD.

1.0	.500	.12	1/4-5/16	SPECIFY
1.5	.750	.08	1/8-3/16	
A	B	C	WIRE DIA.	RAD.

VERTICAL RING WELDING ELECTRODE
RIGHT & LEFT

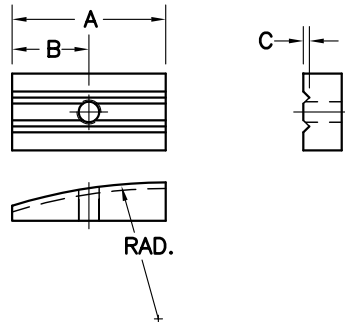

- ORDER GUIDE -
PART NO. KEY:
9701-16- A - B - C - RAD.

1.0	.500	.12	1/4-5/16	SPECIFY
1.5	.750	.08	1/8-3/16	
A	B	C	WIRE DIA.	RAD.

PART DESCRIPTION:
LOWER ELECTRODE L.H. SHOWN (R.H. OPPOSITE) FOR SEEDORFF BUTT WELDING ATTACHMENT.
MADE FROM CLASS 2 COPPER.

UNLESS OTHER-
WISE SPECIFIED,
TOLERANCES:
FRACTIONS=±1/32
DEC .XX=±.015
DEC .XXX=±.005
ANGLES=±1/2°

A.P. SEEDORFF & CO., INC.
RESISTANCE WELDING EQUIPMENT
TEL. 714-252-5330
FAX 714-252-5335
1338 N. KNOLLWOOD CIRCLE, ANAHEIM, CA

SCALE	DWG. SIZE	DWG. NO.	REV.
NONE	A	9701-16	

VERTICAL RING CLAMPING JAWS
RIGHT & LEFT

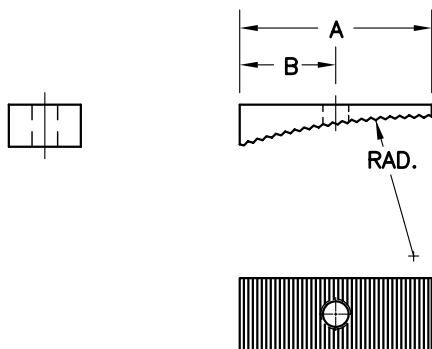

— ORDER GUIDE —
PART NO. KEY:
9701-17- A - B - RAD.

1.0	.500	SPECIFY
1.5	.750	
A	B	RAD.

STRAIGHT CLAMPING JAWS
RIGHT & LEFT

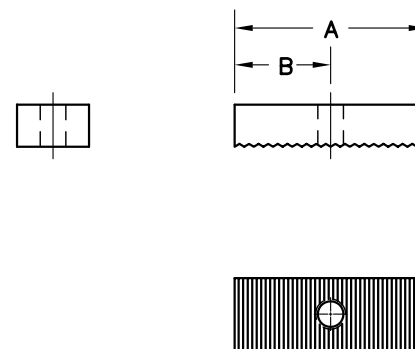

— ORDER GUIDE —
PART NO. KEY:
9701-17- A - B

1.0	.500
1.5	.750
A	B

PART DESCRIPTION:
UPPER JAW CLAMP FOR SEEDORFF BUTT WELDING ATTACHMENT.
MADE FROM HARDENED D-2 TOOL STEEL

UNLESS OTHER- WISE SPECIFIED, TOLERANCES: FRACTIONS=±1/32 DEC .XX=±.015 DEC .XXX=±.005 ANGLES=±1/2°	A.P. SEEDORFF & CO., INC. RESISTANCE WELDING EQUIPMENT TEL. 714-252-5330 FAX 714-252-5335 1338 N. KNOLLWOOD CIRCLE, ANAHEIM, CA		
	SCALE NONE	DWG. SIZE A	DWG. NO. 9701-17