

STRAIGHT WELDING ELECTRODE  
RIGHT & LEFT

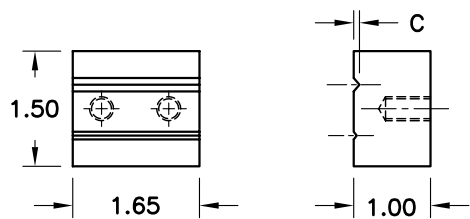

HORIZONTAL RING WELDING ELECTRODE  
RIGHT & LEFT

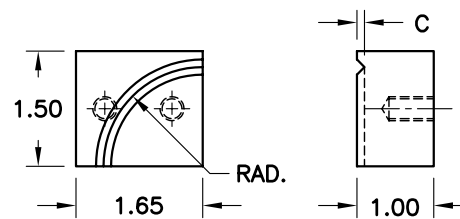

.28	9/16-3/4
.19	3/8-1/2
.13	1/4-5/16
.08	1/8-3/16
C	WIRE DIA.

- ORDER GUIDE -  
PART NO. KEY:  
66A-1-C

.28	9/16-3/4	SPECIFY
.19	3/8-1/2	
.13	1/4-5/16	
.08	1/8-3/16	
C	WIRE DIA.	RAD.

- ORDER GUIDE -  
PART NO. KEY:  
66B-1- C-RAD.

PART DESCRIPTION:  
LOWER ELECTRODE SET L.H. SHOWN (R.H. OPPOSITE) FOR ACME BUTT WELDER.  
MADE FROM CLASS 2 COPPER.

UNLESS OTHER-  
WISE SPECIFIED,  
TOLERANCES:  
FRACTIONS=±1/32  
DEC .XX=±.015  
DEC .XXX=±.005  
ANGLES=±1/2°

**A.P. SEEDORFF & CO., INC.**  
RESISTANCE WELDING EQUIPMENT  
TEL. 714-252-5330  
FAX 714-252-5335  
1338 N. KNOLLWOOD CIRCLE, ANAHEIM, CA

SCALE	DWG. SIZE	DWG. NO.	REV.
NONE	A	66A-1/66B-1	

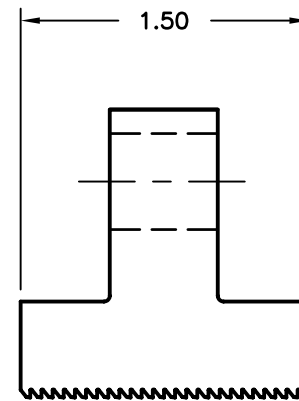
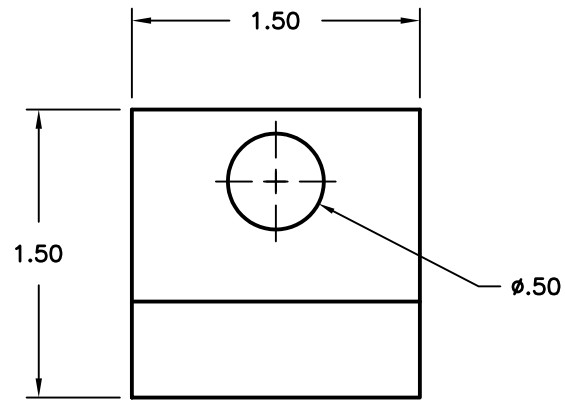

**PART DESCRIPTION:**  
 UPPER JAW CLAMP FOR ACME BUTT WELDER.  
 MADE FROM HARDENED D-2 TOOL STEEL

UNLESS OTHERWISE SPECIFIED, TOLERANCES: FRACTIONS=±1/32 DEC .XX=±.015 DEC .XXX=±.005 ANGLES=±1/2°		A.P. SEEDORFF & CO., INC. RESISTANCE WELDING EQUIPMENT TEL. 714-252-5330 FAX 714-252-5335 1338 N. KNOLLWOOD CIRCLE, ANAHEIM, CA	
SCALE	DWG. SIZE	DWG. NO.	REV.
NONE	A	66A-2	