

NON-PILOTING NUT WELDING ELECTRODES

Phone: 866-RES-WELD (737-9353) Fax: 714-252-5335

www.seedorffwelders.com

NON-PILOTING NUT WELDING ELECTRODES



PART No.	Taper or Thd. Size	Pin Dia. N	Pilot Length L	Pilot Dia. P	For Nut Thd. Size N	Pin Part No.
16-3774-04		.082		.142	#4	16-950001-04
16-3774-05		.093		.158	#5	16-950001-05
16-3774-06		.100		.173	#6	16-950001-06
16-3774-08	5RW	.129	.312	.198	#8	16-950001-08
16-3774-10		.143		.220	#10	16-950001-10
16-3774-M6		.186		.250	6MM	16-950001-M6

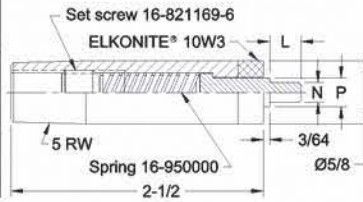

PART No.	Taper or Thd. Size	Pin Dia. N	Pilot Length L	Pilot Dia. P	For Nut Thd. Size N	Pin Part No.
16-3775-12		.166		.250	#12	16-950001-12
16-3775-M6		.186		.250	6MM	16-950001-M6
16-3775-25		.192		.283	1/4	16-950001-25
16-3775-M8	5RW	.252	.312	.283	8MM	16-950001-M8
16-3775-31		.257		.345	5/16	16-950001-31
16-3775-M10		.322		.347	10MM	16-950001-M10

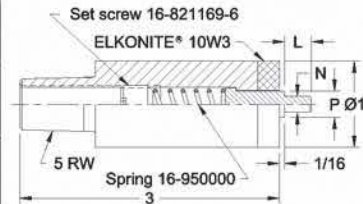

PART No.	Taper or Thd. Size	Pin Dia. N	Pilot Length L	Pilot Dia. P	For Nut Thd. Size N	Pin Part No.
16-3785-12	5/8-18	.166	.375	.250	#12	16-950002-12
16-3785-M6		.186		.269	6MM	16-950002-M6
16-3785-25		.192		.283	1/4	16-950002-25
16-3785-M8		.252		.348	8MM	16-950002-M8
16-3785-31		.257		.345	5/16	16-950002-31
16-3785-M10		.320		.427	10MM	16-950002-M10
16-3785-M11		.359		.466	11MM	16-950002-M11
16-3785-M12		.388		.470	12MM	16-950002-M12

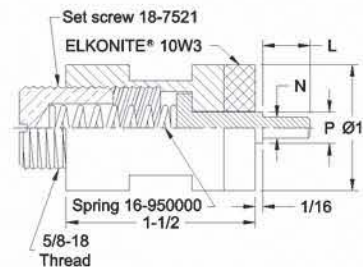

PART No.	Taper or Thd. Size	Pin Dia. N	Pilot Length L	Pilot Dia. P	For Nut Thd. Size N	Pin Part No.
16-3786-12	5/8-18	.166	.375	.250	#12	16-950002-12
16-3786-M6		.186		.269	6MM	16-950002-M6
16-3786-25		.192		.283	1/4	16-950002-25
16-3786-M8		.252		.348	8MM	16-950002-M8
16-3786-31		.257		.345	5/16	16-950002-31
16-3786-38		.306		.408	3/8	16-950002-38
16-3786-M10		.320		.427	10MM	16-950002-M10
16-3786-M11		.359		.466	11MM	16-950002-M11
16-3786-44		.361		.470	7/16	16-950002-44
16-3786-M12		.388		.470	12MM	16-950002-M12
16-3786-50		.415		.533	1/2	16-950002-50

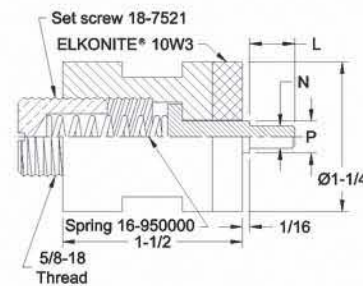

FEATURES AND SPECIFICATIONS

- ELKONITE® 10W3 faced CMW® 3 material
- Insulated pin made of anodized aluminum
- Insulated pins are treated to 55 HRC for wear resistance
- Use with tapered electrode holders
- Use with flat faced electrodes
- Accepts external cooling chambers

TYPICAL SET-UP FOR NON PILOTING NUTS

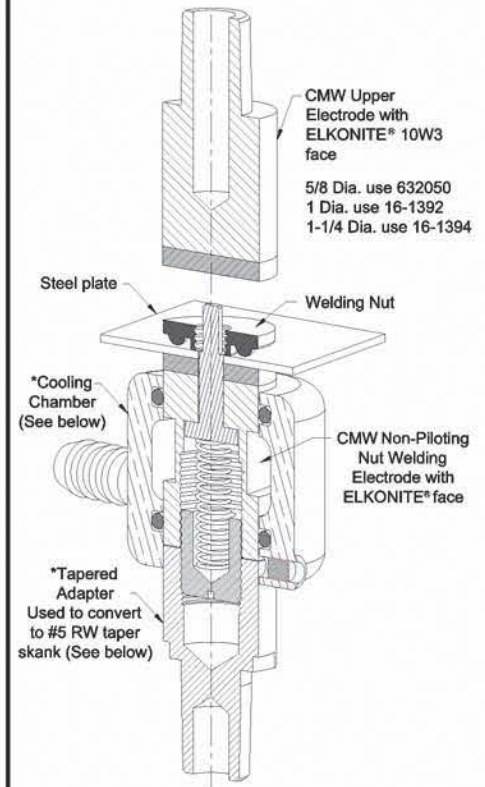

*For additional information on cooling chamber and tapered adapter see page 27

Electrode assemblies 18-3785-XX and 18-3786-XX may be used with 5/8-18 threaded holders 18-169, 18-170, 18-171