

100 SERIES (NON-EJECTOR) WATER COOLED ELECTRODE HOLDER

Phone: 866-RES-WELD (737-9353) Fax: 714-252-5335 www.seedorffwelders.com

100 SERIES (NON-EJECTOR) WATER COOLED ELECTRODE HOLDER

100 SERIES TAPERED HOLDER					
Part No. Holder Assy.	Major Taper Dia. A	Barrel Dia. B	Barrel Length C	RW Taper D	Engagement With Std. Elect. E
18-101	.463	3/4	3	4 RW	1/2
18-102		7/8			
18-103		1			
18-104		1-1/4			
18-106	.625	1	8	5 RW	3/4
18-107		1-1/4			
18-108		1-1/2			
18-111	.463	3/4	8	4 RW	1/2
18-112		7/8			
18-113		1			
18-114		1-1/4			
18-116	.625	1	8	5 RW	3/4
18-117		1-1/4			
18-118		1-1/2			
18-119	.875	1-1/4	12	7 RW	1-1/8
18-120	1-1/2				
18-131	.463	3/4	12	4 RW	1/2
18-132		7/8			
18-133		1			
18-134		1-1/4			
18-136	.625	1	12	5 RW	3/4
18-137		1-1/4			
18-138		1-1/2			

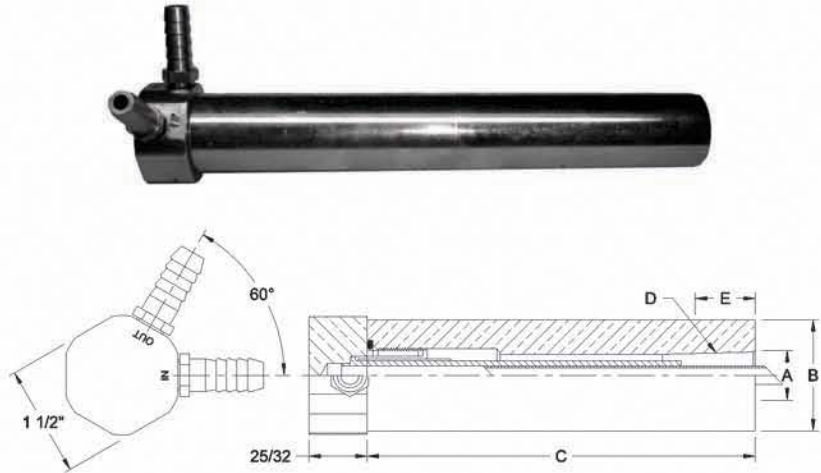

100 SERIES THREADED HOLDER				
Part No. Holder Assy.	Barrel Dia. B	Barrel Length C	Thread Size D	Engagement With Std. Electrode E
18-169	1	8	5/8-18	9/16
18-170	1-1/4			
18-171	1-1/2			
18-172	1	8	7/8-14	9/16
18-173	1-1/4			
18-174	1-1/2			
18-175	1-1/4	8	1-14	3/4
18-176	1-1/2			

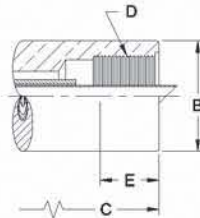

See available adapters in table below.

ADAPTERS USED WITH THREADED HOLDERS

100 SERIES THREADED HOLDER ADAPTERS					
Holder Assembly No.	Adapter Part No.	Page No.	Attachment Description		
18-169 18-170 18-171	Use with 18-750 18-751 18-752 18-811	31	4 RW Female	May also be used with universal Adapters having 7/8-14 Male thread See page 46	
		31	5 RW Female		
		31	5/8-18 M. Thread		
		48	#1 Size Nu-Twist*		
18-172 18-173 18-174	Use with 18-770 18-771	31	4 RW Female	May also be used with universal Adapters having 1-14 Male thread See page 46	
		31	5 RW Female		
		31	7 RW Female		
18-175 18-176	Use with 18-785 18-786 18-7863 18-787 18-812	31	4 RW Female	May also be used with universal Adapters having 1-14 Male thread See page 46	
		31	5 RW Female		
		31	6 RW Female		
		31	7 RW Female		
		48	#2 Size Nu-Twist*		

